

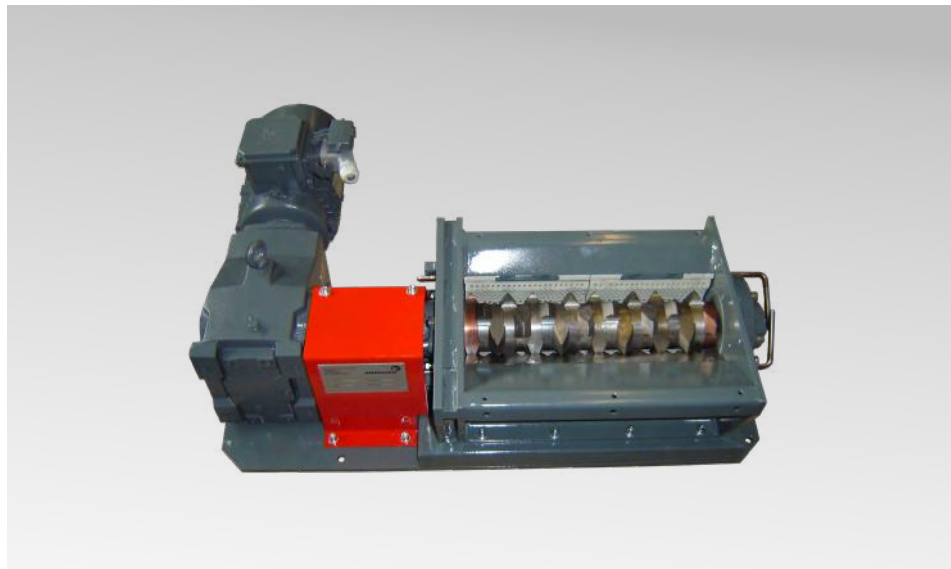

ERDWICH

... SHREDDING UNLIMITED ...

ERDWICH
SINGLE-SHAFT-SHREDDER
M400/1-200
M400/1-400



Advantages and special features

ERDWICH M400/1

■ **Simple maintenance:**

- | Individually fitted, replaceable cutter discs on the cutter rotor

■ **Savings on operating costs:**

- | Long service life guaranteed by cutters fully hardened to permit repeated re-sharpening

■ **Configurable throughput and particle size:**

- | Configurable population of the cutter discs on the cutter rotor and individual perforated screen geometries
- | Optimal feed-in thanks to use of a special pressure angle for the cutters and optimum shredding results even at low speeds

■ **Moist material processing possible:**

- | With externally placed shaft bearings and integrated bulkhead seals, no milled product or liquid materials can enter the bearings.

■ **Low-noise, low-dust operation:**

- | Slow-running rotor

■ **Tailor-made plant, even where space is at a premium:**

- | Custom cutter element models and a range of drive system options

■ **Efficient, safe operation:**

- | PLC unit featuring automated reverse and power cut-offs to protect the machine against damage from overloading or solid parts



ERDWICH

... SHREDDING UNLIMITED ...

ERDWICH SINGLE-SHAFT-SHREDDER M400/1-200 M400/1-400

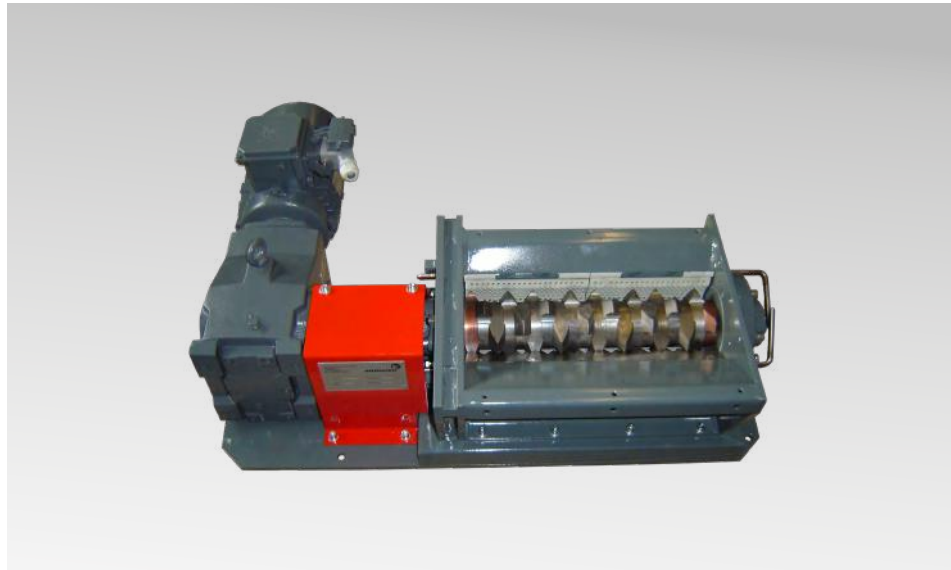

Technical Data

| Type | Number of shafts | Drive power in kW | Cutting unit size (LxW mm) | Weight (kg) | Diameter of punched sieve (mm) | Width of rotor knife (mm) |
|------------|------------------|-------------------|----------------------------|-------------|--------------------------------|---------------------------|
| M400/1-200 | 1 | 2,2 - 3,0 | 200 x 200 | 100 | 6 - 20, 40 | 20 |
| M400/1-400 | 1 | 2,2 - 3,0 | 400 x 200 | 130 | 6 - 20, 40 | 20 |

| Dimensions | | | |
|-----------------------|-----------|------------|------------|
| | Dimension | M400/1-200 | M400/1-400 |
| Cutting unit length X | mm | 200 | 405 |
| Cutting unit width Y | mm | 215 | 215 |
| Cutting unit height Z | mm | 200 | 200 |
| Total length A1 | mm | 985 | 1185 |
| Total length A2 | mm | 720 | 920 |
| Total width B1 | mm | 398 | 398 |
| Total width B2 | mm | 365 | 365 |
| Total height C1* | mm | 210 | 210 |
| Total height C2* | mm | 626 | 626 |

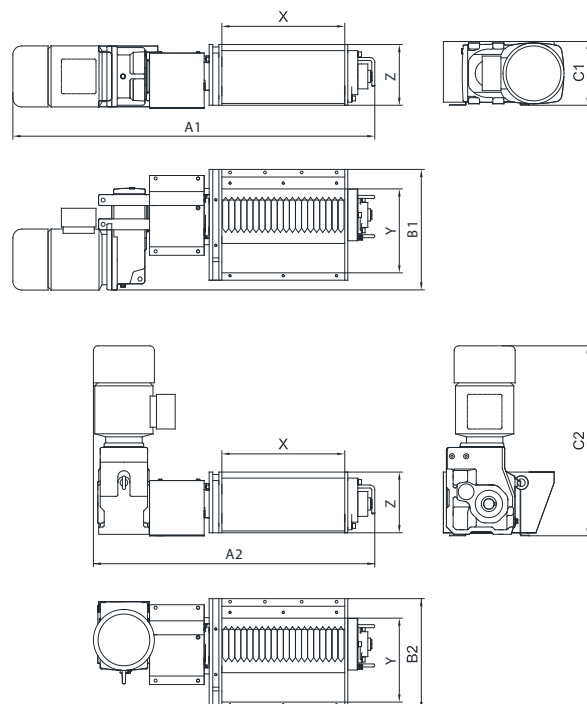

Subject to technical changes.

*variable, depending on drive concept